



Swing bolt closure for quick and secure filter change-outs

Heavy duty 304 stainless steel

Legs are standard

HYDRONIX BF SERIES BAG FILTER HOUSINGS

are ideal for most industrial/commercial applications. Our welded leg design as a standard feature, eliminates the added expense to your application. Commonly used for pre-filtration to reverse osmosis (RO) systems, farms, food service, car washes, agriculture and many other uses.

HYDRONIX BF SERIES BAG FILTER HOUSINGS

use a high grade 304 stainless steel as standard (not "L"), which is a lower grade stainless steel used by other brands.



BF SERIES

Stainless Steel Bag Filter Housings

Materials of Construction

Housing:	304 stainless steel
Closure:	Stainless Steel
O-Ring:	EPDM (FDA Grade)

Operating Data

Max. Pressure/Temp:	150 PSI at 200°F (10.34 bar at 93.33°C)
---------------------	--

Standard Features

- Electropolished
- Adjustable legs



Port Dimensions

Vent:	1/4" NPT
Inlet:	2" NPT
Outlet:	2" NPT
Drain:	3/4" NPT

Basket Dimensions

For BF1:	13.78" x 6.75" (350mm x 171.5mm)
For BF2:	28.74" x 6.75" (730mm x 171.5mm)

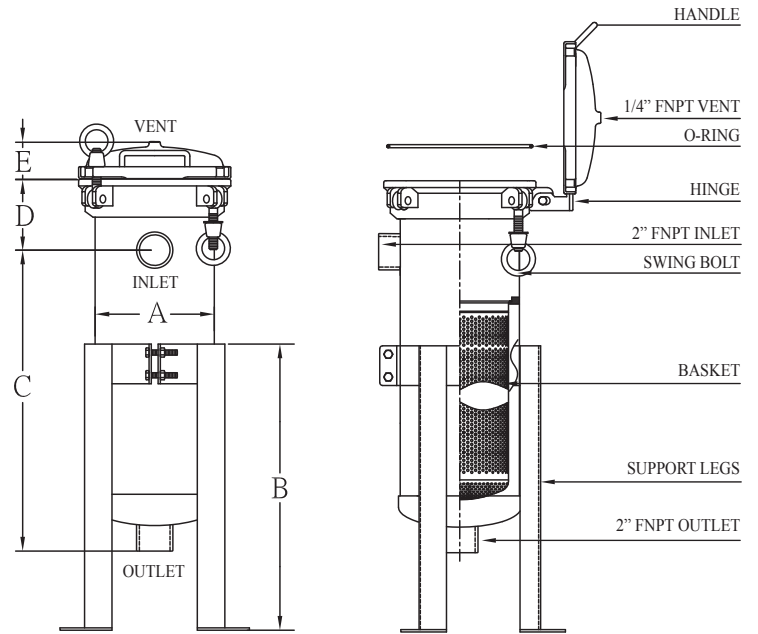
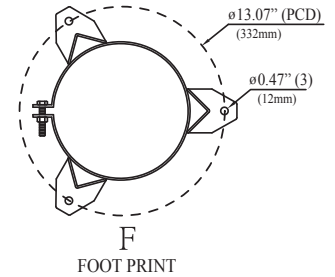
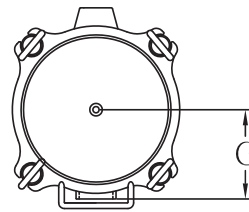

Bag Filter Housing Dimensions

BF SERIES SPECIFICATIONS			
Part Number	Description	FLOW RATE	
		GPM	LPM
BF1-304-2N	304SS Bag Filter Housing, 150 PSI, 2" FNPT	90	341
BF2-304-2N	304SS Bag Filter Housing, 150 PSI, 2" FNPT	180	681

Model	A Body Width	B Legs Length	C Outlet to Inlet	D Inlet to cover	E Cover	F Foot Print Radius (PCD)	G Hinge to Vent
BF1	8.86 in 210 mm	19.84 in 504 mm	20.86 in 530 mm	4.92 in 125 mm	2.55 in 65 mm	ø 13.07 in ø 332 mm	5.62 in 143 mm
BF2	8.86 in 210 mm	27.71 in 704 mm	35.82 in 910 mm	4.92 in 125 mm	2.55 in 65 mm	ø 13.07 in ø 332 mm	5.62 in 143 mm

Flow rates are based on water and are for guidelines only.

LIT-BF-SS 05/02/16

HYDRONIX WATER TECHNOLOGY

P.O. Box 2235 Chino Hills, CA 91709 | USA
sales@hydronixwater.com • www.HydronixWater.com

Distributed by: